

**PRESSURE REDUCING VALVE
DIRECT ACTING
PRV25I – Stainless steel (CF8M)**

DESCRIPTION

The ADCA PRV25I series direct acting pressure reducing valves are designed for use on steam, compressed air and other gases.

They are suitable for reducing steam pressure at the point of use on laundry machines, dyeing, food industries, sterilizers, etc.

Connections are female screwed or flanged.

MAIN FEATURES

Compact design.

Bellows specially designed for high durability.

Built-in strainer.



OPTIONS: Regulating screw with top cap.

USE: Saturated steam, compressed air and other gases compatible with the construction.

AVAILABLE MODELS:
 PRV25 I – metal to metal seating
 PRV25IG – soft valve
 PRW25I – soft valve balanced

RECOMMENDED APPLICATIONS :
 PRV25I – steam and compressed air
 PRV25IG – steam and compressed air where tight off is required
 PRW25I – water, compressed air

SIZES: ½", ¾", 1"; DN15, DN 20 and DN 25.

CONNECTIONS: Female screwed ISO7/1Rp(BS 21) .
 Flanged EN 1092-1 PN40 or ANSI.

INSTALLATION: Horizontal installation.
 An "Y" strainer should be provided upstream the valve.
 See IMI, installation and maintenance instructions.



CE MARKING (PED - European Directive 97/23/EC)	
PN 25	Category
DN 15 to 25	SEP - art. 3, paragraph3

LIMITING CONDITIONS			
	PRV25I	PRV25IG	PRW25I
Body design conditions	PN25	PN25	PN25
Max.upstream pressure	17 bar	17 bar	14 bar
Max.downstream pressure	8,6 bar	8,6 bar	8,6 bar
Min.downstream pressure	0,14 bar	0,14 bar	0,35 bar
Max.design temperature	210°C	180°C	75°C
Max.cold hydraulic test	38 bar	38 bar	38 bar
Max.reducing ratio	10:1	10:1	10:1

CAPACITIES (See selection table)			
Valve Size	15	20	25
KVs	1,7	2,6	3,1

PRESSURE RANGES				
Spring colour	Blue *	Yellow **	Green	Red
Red.Press. bar	0,35 - 1,7	0,14 - 1,7	1,4 - 4,0	3,5 - 8,6

*Applicable only on the PRW ; ** Appl.only on the PRV
Where control spring ranges overlap,always use the lower range.

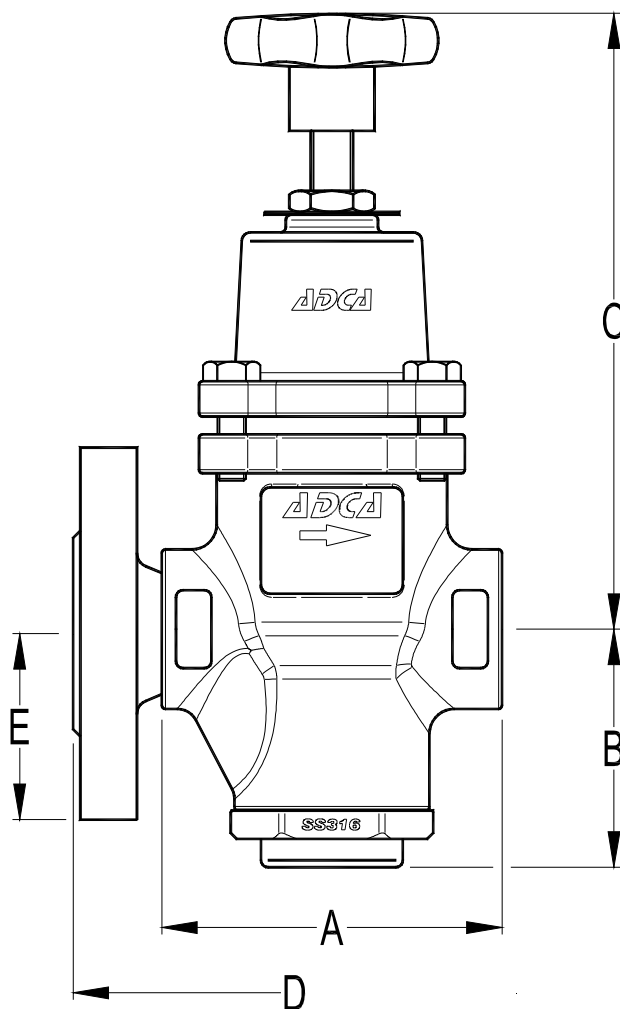

SIZE DN	DIMENSIONS (mm)-Screwed				EN1092-1 Flanges			
	A	B	C	F	WGT. Kgs	D	E	WGT. Kgs
1/2"	96	68,5	175	74	3	150	47,5	4,4
3/4"	96	68,5	175	74	3	150	52,5	5
1"	96	68,5	175	74	2,9	160	57,5	5,5

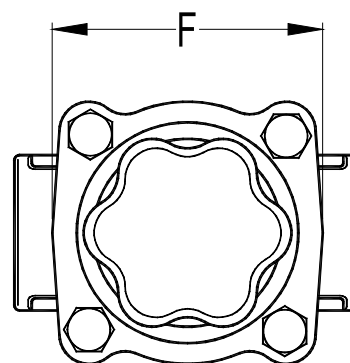

MATERIALS		
POS.	DESIGNATION	MATERIAL
1	VALVE BODY	CF8M / 1.4408
2	COVER	CF8M / 1.4408
3	*SEAT	AISI 316 / 1.4401
4	*GASKET	COPPER
5	*VALVE	HARDENED ST. STEEL
5.1	*O-RING	NBR
5.2	*VALVE HEAD	NBR
5.3	*VALVE HEAD	PTFE/GRAPHITE
6	*VALVE RETURN SPRING	AISI 302 / 1.4300
7	*STRAINER SCREEN	AISI 304 / 1.4301
8	PUSHROD	AISI 316 / 1.4401
9	BOTTOM CAP	CF8M / 1.4408
10	*CAP GASKET	ST. ST. / GRAPHITE
11	COVER BOLTS	STAINLESS STEEL
12	GUIDE BUSH HOUSING	AISI 316 / 1.4401
12.1	*GUIDE BUSH	PTFE/GRAPHITE
13	*STOP RING	AISI 304 / 1.4301
14	*BELLOWS	AISI316Ti / 1.4571
15	*BELLOWS GASKET	ST. ST. / GRAPHITE
16	*ADJUSTMENT SPRING	STEEL
17	TOP SPRING PLATE	BRASS /
18	ADJUSTMENT SCREW	AISI 304 / 1.4301
19	LOCKNUT	AISI 304 / 1.4301
20	HANDWHEEL	PLASTIC
21	SPRING IDENT. PLATE	ALUMINIUM

* Available spare parts.

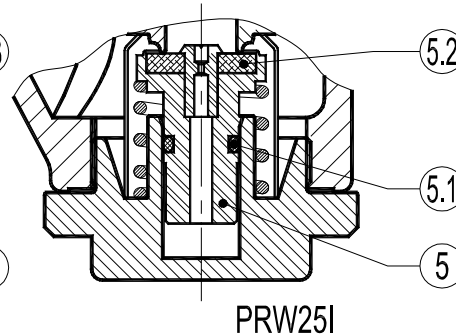
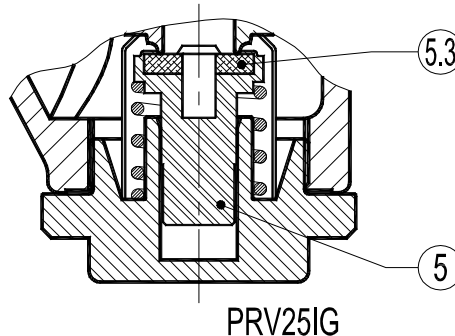
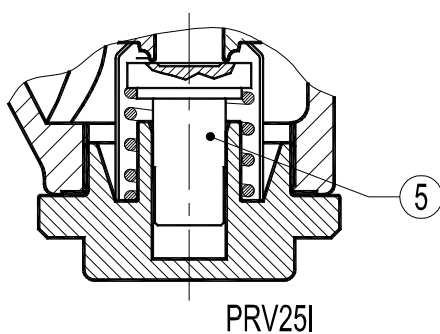
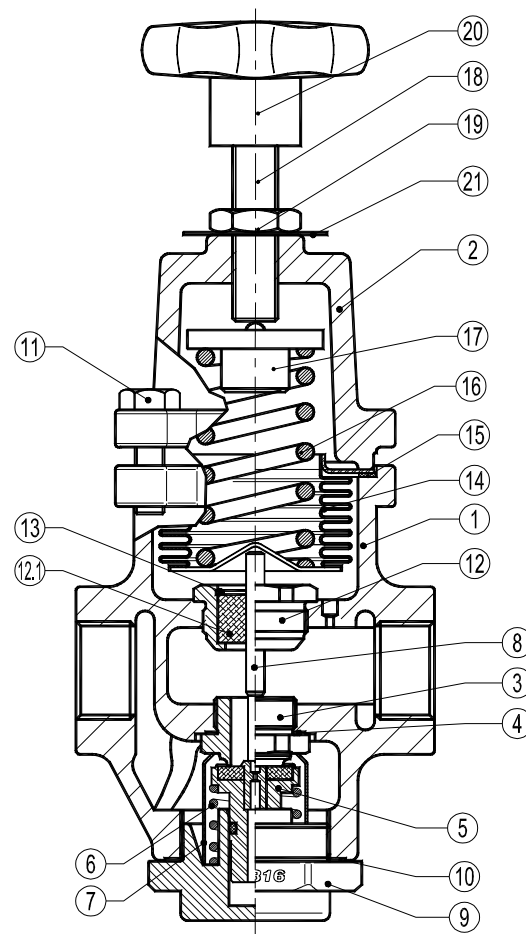



STEAM CAPACITY TABLE (Kg/h)				
INLET bar	OUTLET bar	SAT. STEAM		
		DN15	DN20	DN25
2	0,2	33	53	64
	1,2	57	87	104
	1,6	38	59	71
3	0,3	45	70	83
	1,2	76	116	138
	2,2	61	93	111
	2,6	46	70	83
4	0,4	56	87	104
	1	66	102	121
	2,5	95	145	173
	3,5	57	87	104
5	0,5	68	105	125
	2	91	139	166
	3	114	174	208
	4	85	130	155
6	0,6	79	122	145
	2	106	162	194
	3	133	203	243
	4	120	184	219
7	0,7	91	139	167
	2	121	185	222
	3,5	152	232	277
	5	132	201	240
8	0,8	102	157	187
	2	137	210	250
	3,5	171	262	312
	5	161	247	294
	6	142	217	259
9	0,9	114	174	208
	2,5	133	203	242
	4	152	233	277
	5	190	291	347
10	7	152	232	277
	1	125	192	228
	3	146	224	266
	4	167	256	305
	6	209	320	381
11	8	161	247	294
	1,1	136	210	249
	3	182	280	333
	6	228	350	416
	8	198	302	360
12	8,6	182	279	331
	1,2	148	227	270
	3	197	302	360
	6	247	378	451
	8	228	349	416
13	8,6	217	332	396
	1,3	159	244	291
	4	186	284	340
	6	212	325	388
	7	266	407	486
15	8,6	246	378	451
	1,5	182	259	321
	4	212	302	374
	6	243	345	427
	8	304	433	536
17	8,6	298	426	512
	1,7	205	279	333
	4	238	325	386
	6	273	372	441
	8	342	465	555
17	8,6	339	449	541

COMPRESSED AIR CAPACITY TABLE (Nm3/h-0°C-1,013bar)				
INLET bar	OUTLET bar	COMPRESSED AIR		
		DN15	DN20	DN25
2	0,2	45	72	86
	1,2	77	117	140
	1,6	51	80	96
3	0,3	61	95	112
	1,2	103	157	186
	2,2	82	126	150
	2,6	62	95	112
4	0,4	76	117	140
	1	89	138	163
	2,5	128	196	234
	3,5	77	117	140
5	0,5	92	142	169
	2	123	188	224
	3	154	235	281
	4	115	176	209
6	0,6	107	165	196
	2	143	219	262
	3	180	274	328
	4	162	248	296
7	0,7	123	188	225
	2	163	250	300
	3,5	205	313	374
	5	178	271	324
8	0,8	138	212	252
	2	185	284	338
	3,5	231	354	421
	5	217	333	397
	6	192	293	350
	0,9	154	235	281
9	2,5	180	274	327
	4	205	315	374
	5	257	393	468
	7	205	313	374
10	1	169	259	308
	3	197	302	359
	4	225	346	412
	6	282	432	514
11	8	217	333	397
	1,1	184	284	336
	3	246	378	450
	6	308	473	562
	8	267	408	486
12	8,6	246	377	447
	1,2	200	306	365
	3	266	408	486
	6	333	510	609
	8	308	471	562
13	8,6	293	448	535
	1,3	215	329	393
	4	251	383	459
	6	286	439	524
	7	359	549	656
15	8,6	332	510	609
	1,5	246	350	433
	4	286	408	505
	6	328	466	576
	8	410	585	724
17	8,6	402	575	691
	1,7	277	377	450
	4	321	439	521
	6	369	502	595
	8	462	628	749
17	8,6	458	606	730

WATER CAPACITY TABLE (m3/h)			
D.P. bar	WATER		
	DN15	DN20	DN25
1,5	2,1	3,18	3,8
2	2,4	3,67	4,38
3	2,95	4,5	5,37
4	3,4	5,2	6,2
5	3,8	5,8	6,93
6	4,16	6,36	7,6
8	4,8	7,35	8,75
12	5,8	9	10,7